

USER GUIDE: 17 118 6004 08/19 Rev A

Maintenance Guide: 171186001

Installation & Setup Guide: 171186002

OIL-X COMPRESSED AIR FILTER

Filters for Compressed Air

P010 - P055 (WS, A0, AA, ACS)

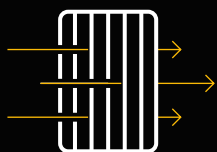

**Filtration
User Guide**

(EN)



CONTENTS

04	- Installing the OIL-X System	14	- Video: How-To Guide
05	- Installation Recommendations	16	- Model Coding - Water Separator Flow Rates
07	- Start-Up Procedure - Running Configuration	17	- Filter Flow Rates - Technical Data
09	- Maintenance Intervals	18	- Water Separator Weights and Dimensions
10	- System Depressurisation - Filter Bowl Removal	19	- Filter Weights and Dimensions
11	- Removal of Element from Filter Bowl - Automatic Drain Replacement	20	- Filter Flow Rates
12	- Insertion of Replacement Element into Filter Bowl - Replacement of Filter Head O Ring Seal - Reconnecting the Filter Bowl with Head	21	- Accessories / Spare Parts
13	- Service Reminder Label - System Start-up Procedure	22	- Declaration of Conformity
		23	- Parker Worldwide

INSTALLATION RECOMMENDATIONS

INSTALLING THE OIL-X SYSTEM

DIFFERENTIAL PRESSURE INDICATOR

Fitted as standard to AA & AO filters.

Hand tighten mounting screws and then torque to 2.5 Nm in sequence as shown - 1,2,3,4

No DPI fitted to ACS or WS models.

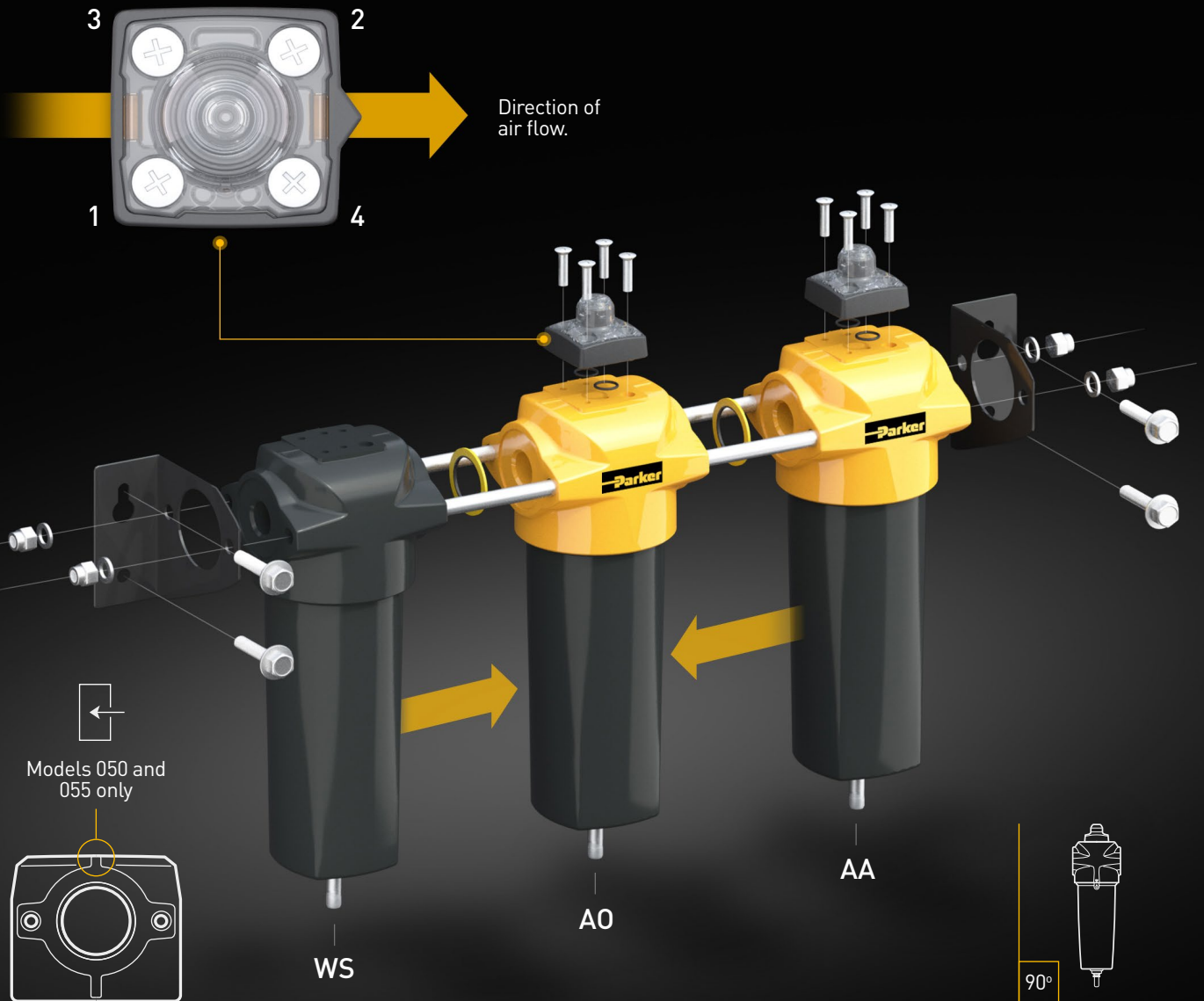

Before pressurising the filter ensure that the head and bowl are correctly fitted and that the locking detail is properly aligned as shown in the maintenance section of this manual.

MODELS 050 AND 055 ONLY

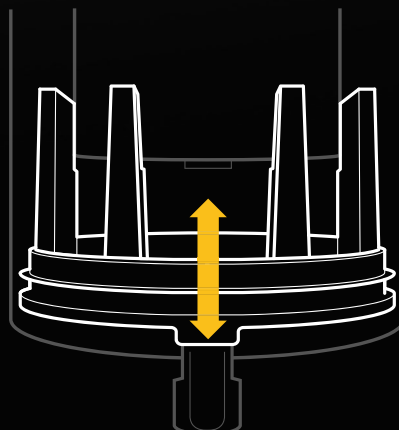

The lower closure plate may move when the filter is not pressurised

The lower closure plate is a non serviceable item and should never be removed.

INSTALLATION RECOMMENDATIONS

- It is recommended that the compressed air is treated prior to entry into the distribution system and also at critical usage points / applications.
- Installation of compressed air dryers to a previously wet system could result in additional dirt loading for point of use filters for a period whilst the distribution system dries out.
- Filter elements may need to be changed more frequently during this period.
- For installations where oil-free compressors are used, water aerosol and particulate are still present, general purpose and high efficiency grades should still be used.
- A general purpose filter must always be installed to protect the high efficiency filter from bulk liquid aerosols and solid particulate.
- Install purification equipment at the lowest temperature above freezing point, preferably downstream of after coolers and air receivers.
- Point of use purification equipment should be installed as close to the application as possible.
- Purification equipment should not be installed downstream of quick opening valves and should be protected from possible reverse flow or other shock conditions.
- Purge all piping leading to the purification equipment before installation and all piping after the purification equipment is installed and before connection to the final application.
- If by-pass lines are fitted around purification equipment, ensure adequate filtration is fitted to the by-pass line to prevent contamination of the system downstream.
- Fit drain lines from the coalescing filters directly to a condensate separator. If it is not possible to connect the drain lines directly to a separator, the lines should be vented in to a condensate manifold (vented at one end) and then in to a single inlet of a condensate separator.
- Provide a facility to drain away collected liquids from the purification equipment.
- Collected liquids should be treated and disposed of in a responsible manner.

START-UP PROCEDURE

START-UP PROCEDURE

Before pressurising the filter ensure that the head and bowl are correctly fitted and that the locking detail is properly aligned. Slowly open the inlet valve (01) to gradually pressurise the filter and wait 1 minute (02) before slowly opening the outlet valve (03) to re-pressurise the downstream piping.

Note: Do not open inlet or outlet valves rapidly or subject unit to excessive pressure differential as damage may occur.

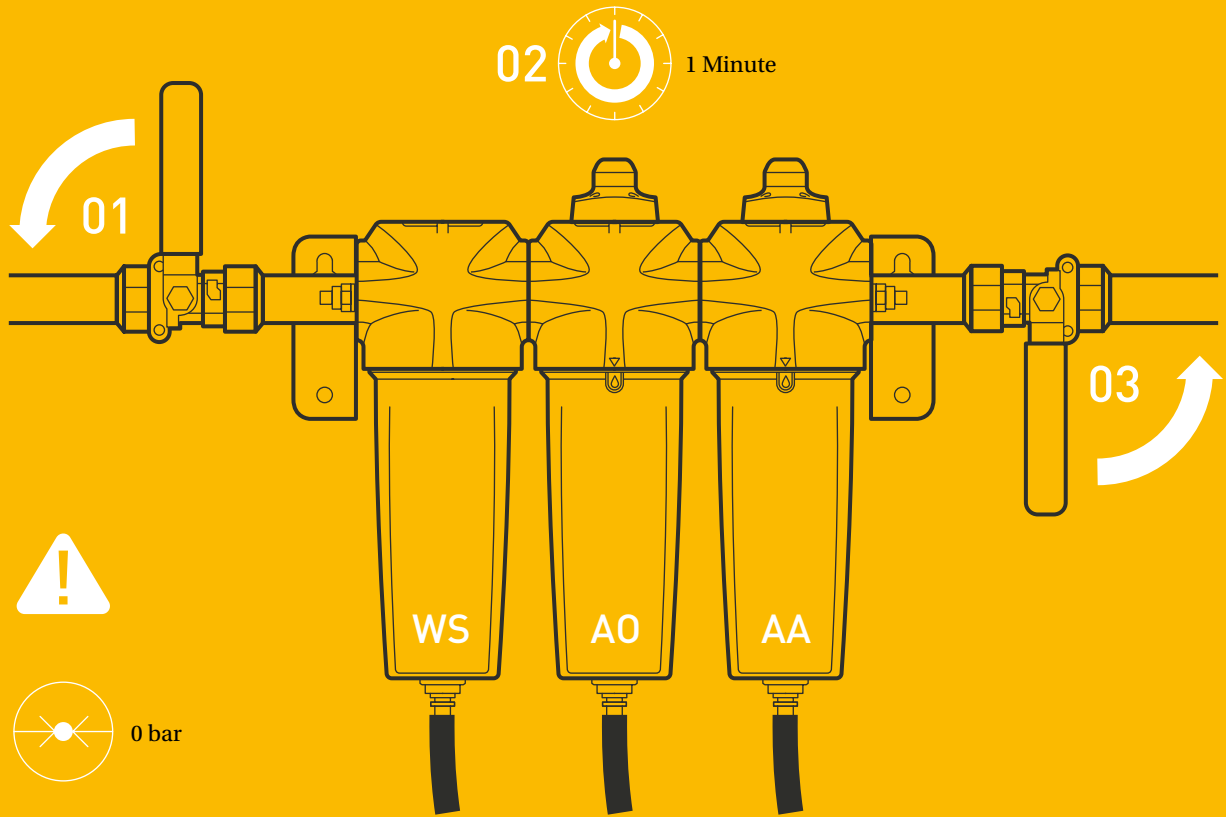

RUNNING CONFIGURATION

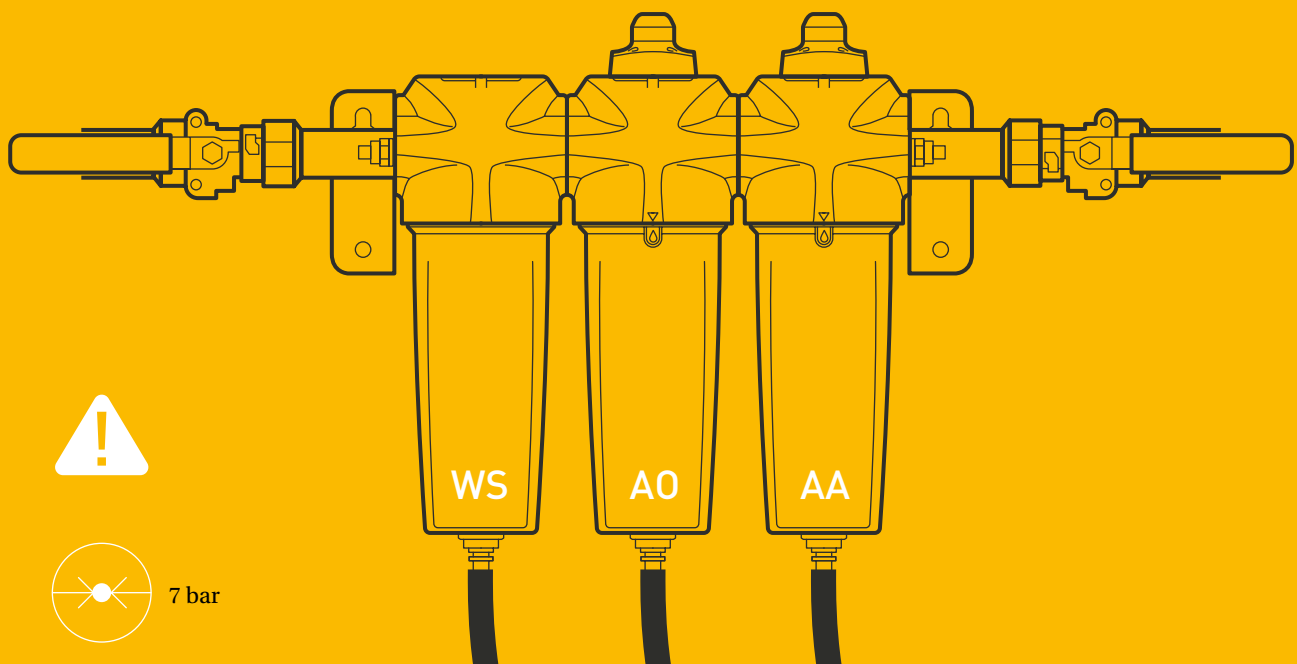

PRODUCT MAINTENANCE

MAINTENANCE INTERVALS

To ensure optimal filter performance the OIL-X Grade AO and OIL-X Grade AA coalescing and dry particulate filter elements require changing every 12 months (8736 hours) along with the automatic float drain.

Unlike coalescing and dry particulate filter elements which are changed annually to guarantee compressed air quality, the lifetime of an adsorption filter element / cartridge can be attributed to various factors and will require more frequent changes. Factors affecting the lifetime of adsorption filters are:

Oil vapour concentration

The higher the inlet concentration of oil vapour, the faster the adsorption material capacity will be used, resulting in reduced adsorption filter element / cartridge lifetime.

Bulk oil

Adsorption filters are designed only to reduce oil vapours and odours, not liquid oil or oil aerosols. Poorly maintained or non-existent pre-filtration (coalescing filters) will cause the adsorption filter capacity to be used quickly resulting in reduced adsorption filter element / cartridge lifetime.

Temperature

Oil vapour content increases exponentially to inlet temperature, reducing adsorption filter element / cartridge lifetime. Additionally, as temperature increases, the adsorption capacity of the adsorbent material decreases, again reducing adsorption filter element / cartridge lifetime.

Relative Humidity or Dewpoint

Wet air reduces the adsorptive capacity of the adsorbent material, reducing adsorption filter element / cartridge lifetime. Ideally, in-line adsorption filters should always be placed downstream of a compressed air dryer to prolong adsorption filter element / cartridge lifetime.

Compressor oil changes

When compressor oil is changed, the new lubricant burns off "light ends" which increases the oil vapour content for hours or even weeks afterwards. This increase in oil vapour content is adsorbed by the adsorption filter element / cartridge, reducing the adsorption filter element / cartridge lifetime.

OIL-X Grade ACS Adsorption Filters

The performance of the OIL-X Grade ACS element is based upon a nominal inlet temperature of 21°C, with a pressure dewpoint of -40°C and a maximum oil vapour inlet concentration of 0.018mg/m³. Under these conditions, OIL-X Grade ACS will have a lifetime of 650 hours. Operating OIL-X grade ACS at higher inlet temperatures / higher inlet oil vapour concentrations / or before a refrigeration or adsorption dryer will result in lower adsorption filter lifetime. Replace the carbon filter element upon detection of vapour, odour or taste. OIL-X Grade ACS are recommended for point of use applications only where frequent element changes are acceptable.

OIL-X Grade OVR Adsorption Filters

Unlike in-line adsorption filters (OIL-X Grade ACS), OIL-X Grade OVR adsorption filters are sized and selected to not only provide consistent air quality but to also provide 12 months of cartridge life. This 12 month (6000 hours for models OVR 100 ~ OVR 250 and 8736 hours for models OVR 300 ~ OVR 550) cartridge life is dependent upon sizing for the following inlet parameters: maximum inlet temperature / compressor type, minimum inlet pressure, position in system (before or after a dryer) and inlet oil vapour content. OIL-X Grade OVR adsorption filters are designed for both plant scale (compressor room) and point of use applications.

SYSTEM DEPRESSURISATION

Slowly close the inlet (01) and outlet (02) valves and depressurise the filter (03) using the drain.

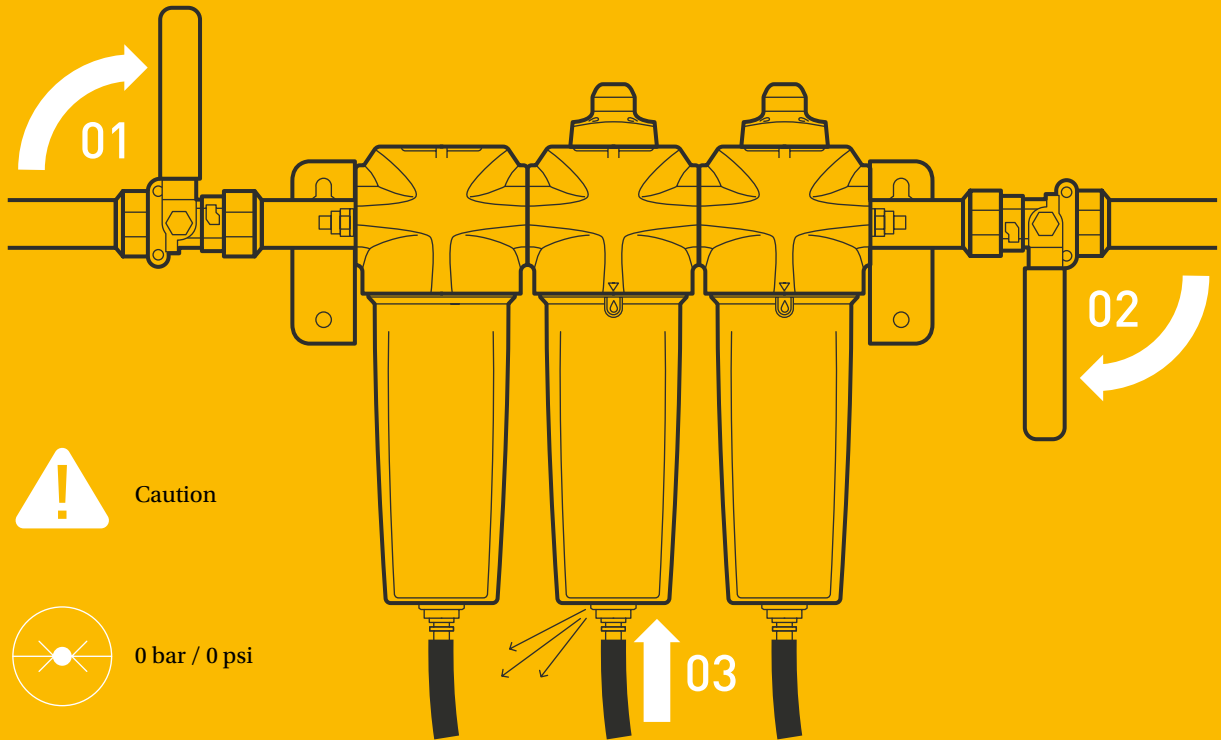

FILTER BOWL REMOVAL

Unscrew the filter bowl (01 & 02) and remove the used element (03).

Note: A strap wrench may be required for the removal of the 050 & 055 filter bowl.

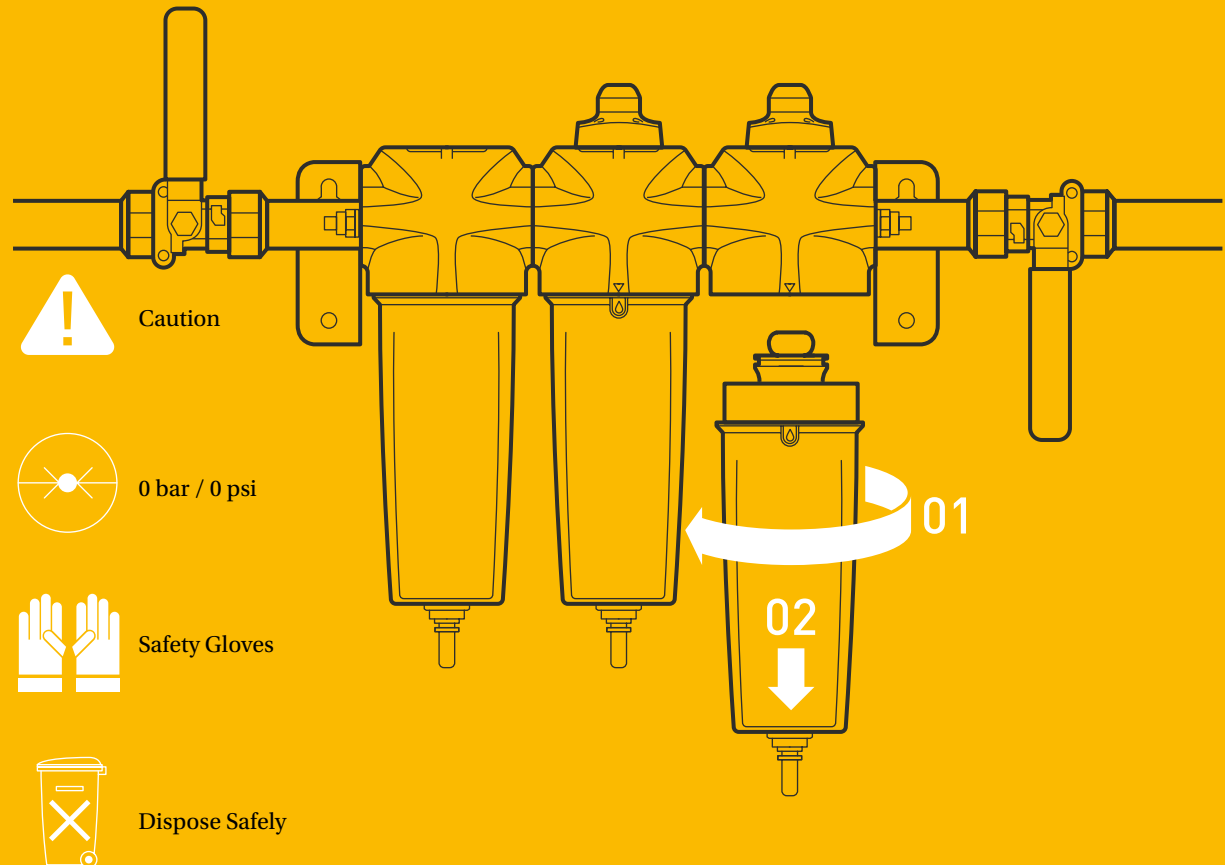

REMOVAL OF ELEMENT FROM FILTER BOWL

Remove the element from the filter bowl.

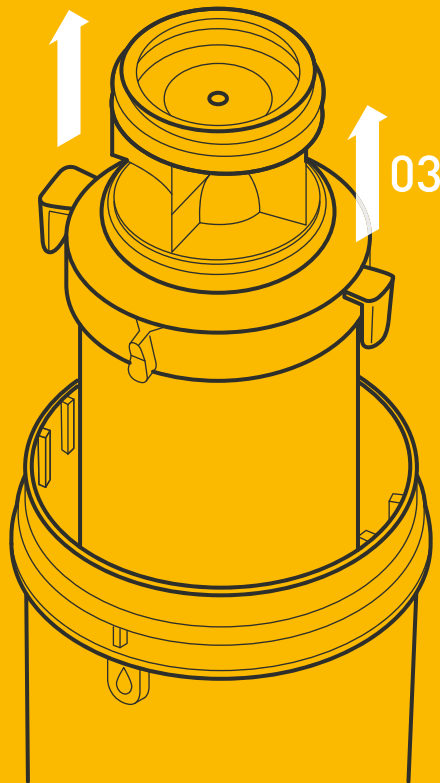

AUTOMATIC DRAIN REPLACEMENT

Unscrew the automatic drain (01) and discard (02). Fit the new drain (03) and tighten (04).

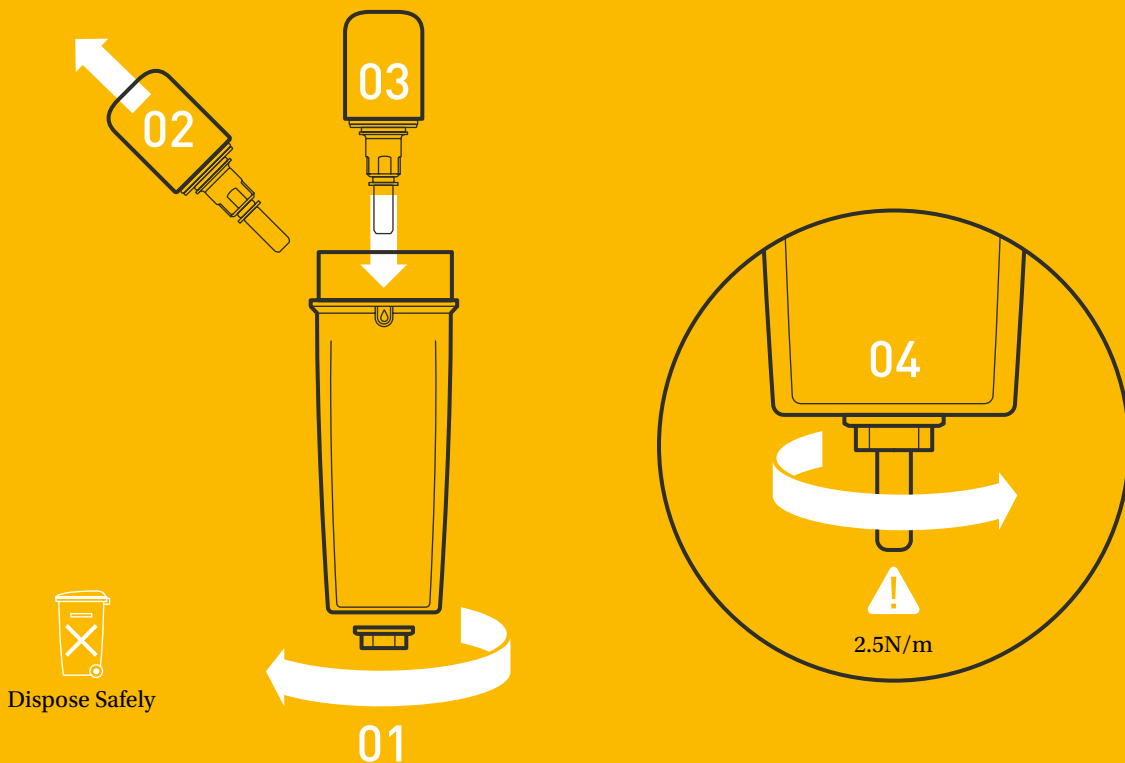

Dispose Safely

INSERTION OF REPLACEMENT ELEMENT INTO FILTER BOWL

Insert the new element into the filter bowl ensuring that the lugs are seated correctly in the grooves.

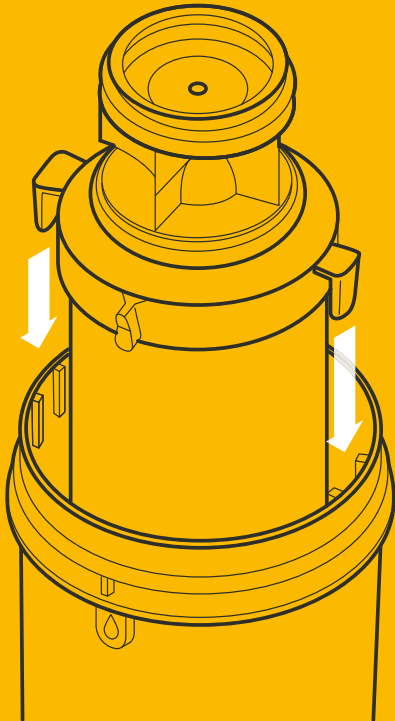

REPLACEMENT OF FILTER HEAD O RING SEAL

Replace the O-ring located in the filter head with the new O-ring provided.

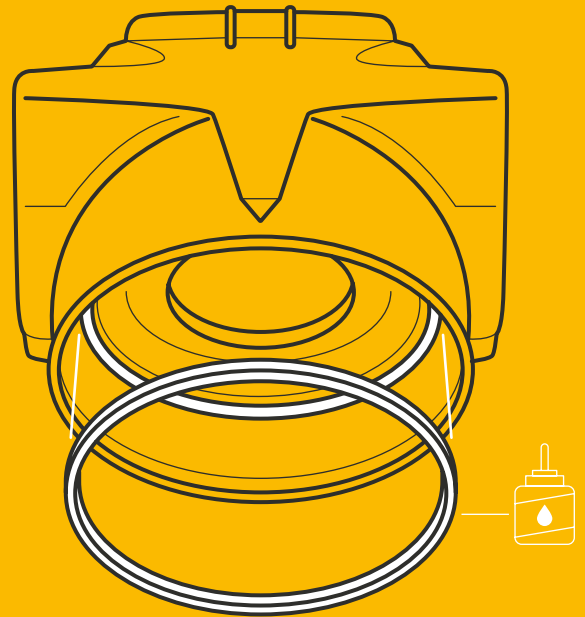

Ensure to lubricate the O-ring and threads with a suitable acid free Petroleum jelly.

RECONNECTING THE FILTER BOWL WITH HEAD

Refit the filter bowl and head ensuring that the threads are fully engaged (01) and the locking details are aligned (02).

Note: To ensure that the bowl is fully engaged into the head, the 010-030 bowl requires 360° of rotation until the thread stop, 720° for the 035-045 bowl and 540° for the 050-055 bowl.

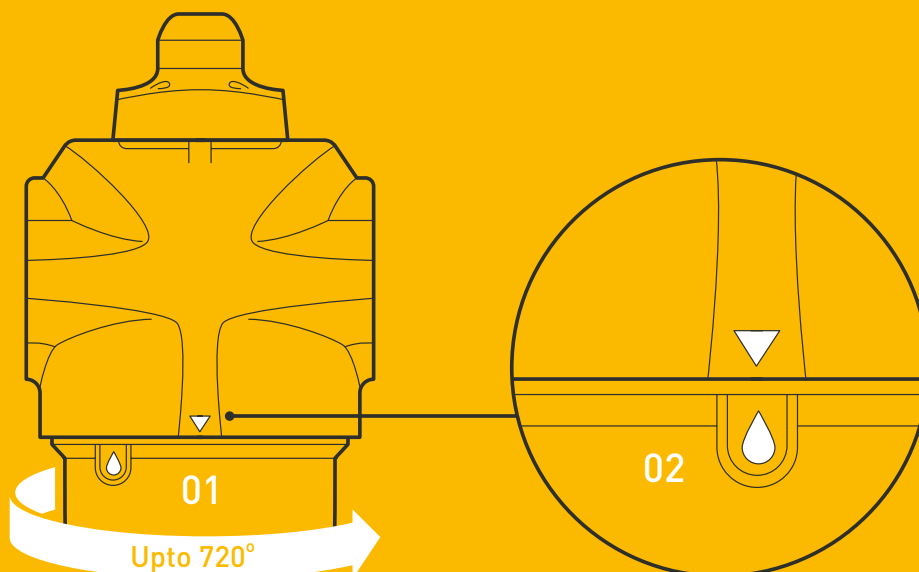

SERVICE REMINDER LABEL

Attach the element change date label to the filter bowl and write on the date the element is to be replaced. i.e 12 months after element change.



Do not use solvents or alcohol to clean the labels as this could cause damage.



0 bar / 0 psi

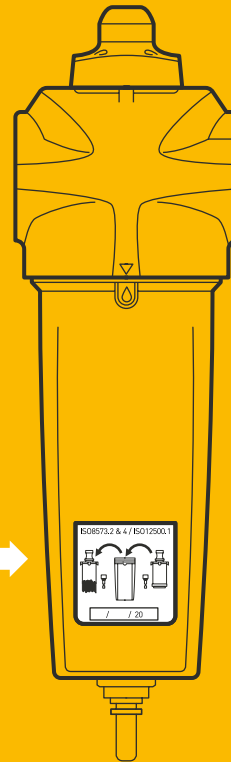
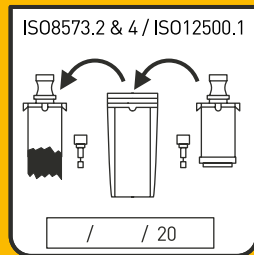

SYSTEM START UP PROCEDURE

Slowly open the inlet valve (01) to gradually pressurise the filter and wait 1 minute (02) before slowly opening the outlet valve (03) to re-pressurise the downstream piping.

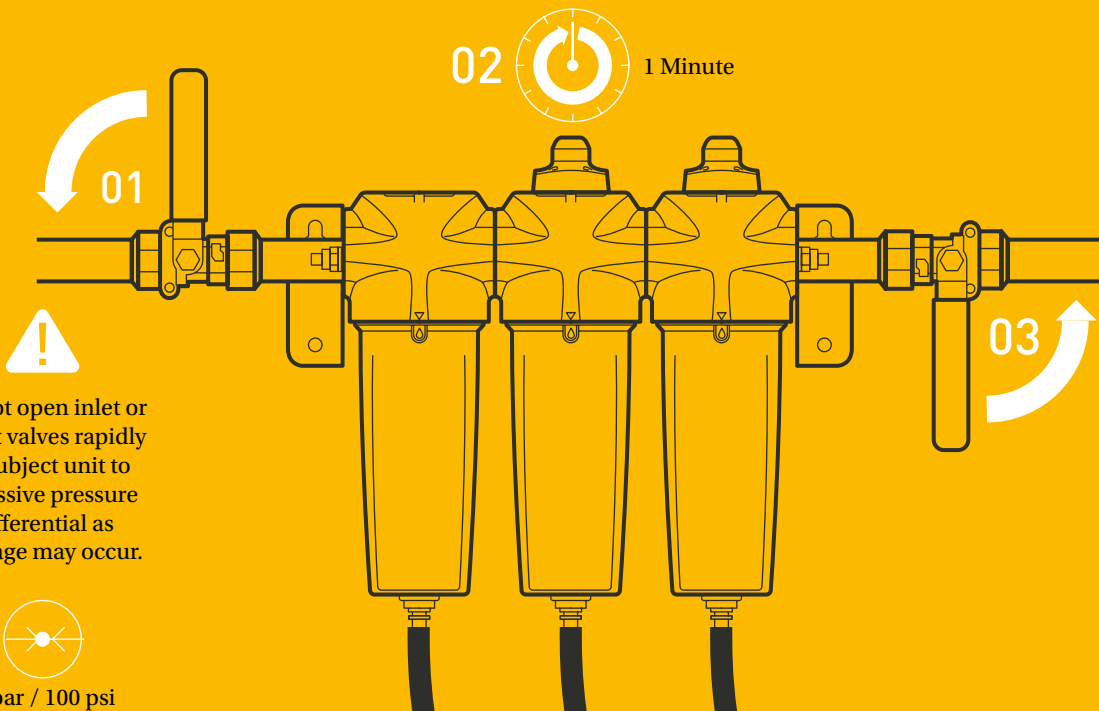

STILL STUCK? WATCH THE HOW-TO GUIDE

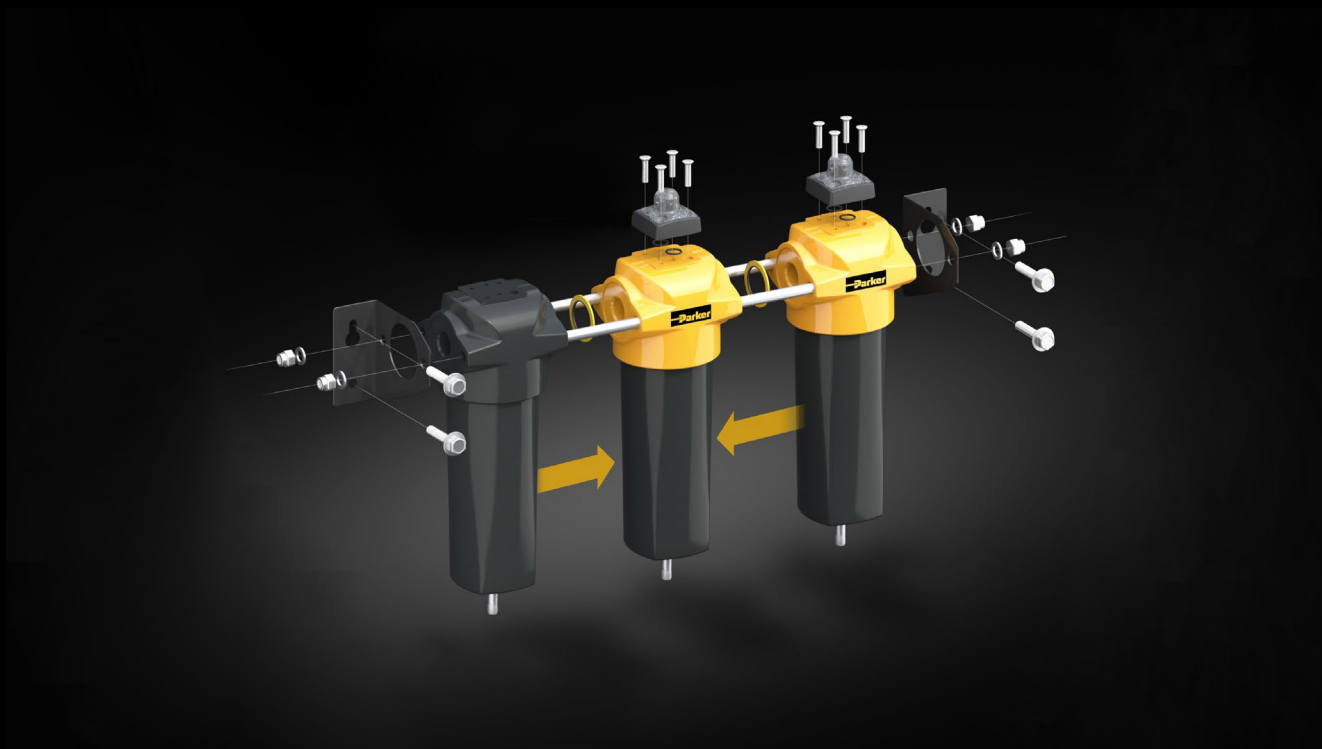

Watch this guide via [Parker Hannifin](#)

WHAT YOU'LL FIND IN THIS VIDEO

Installing the OIL-X System

Start-up Procedure

System De-pressurisation

Filter Bowl Removal

Removal of Element from Filter Bowl

Automatic Drain Replacement

Insertion of Replacement Element into Filter Bowl

Replacement of Filter Head O Ring Seal

Reconnecting the Filter Bowl with Head

Service Reminder Label

System Start-up Procedure

TECHNICAL SPECIFICATION

MODEL CODING EXAMPLE

PRODUCT SELECTION

Stated flows are for operation at 7 bar g (100 psi g) with reference to 20°C, 1 bar a, 0% relative water vapour pressure.

For flows at other pressures apply the correction factors shown.

MODEL						
ELEMENT GRADE	PREMIUM ENERGY EFFICIENT ELEMENT	MODEL SIZE	PORT SIZE	THREAD TYPE	DRAIN OPTION	DP INDICATOR
WS AO AA ACS	P	3 digit code as shown below	A = 1/4" B = 3/8" C = 1/2" D = 3/4" E = 1" G = 1 1/2" H = 2" I = 2 1/2" J = 3"	G = BSPP N = NPT	F = Float M = Manual	X = None I = Incident Monitor
AA	P	030	A	G	F	I

WATER SEPARATOR FLOW RATES

MODEL		PORT SIZE	L/S	M ³ /MIN	M ³ /HR	CFM
WS	P010A [] [] []	1/4	10	0.6	36	21
WS	P010B [] [] []	3/8	10	0.6	36	21
WS	P010C [] [] []	1/2	10	0.6	36	21
WS	P015C [] [] []	1/2	40	2.4	144	85
WS	P020D [] [] []	3/4	40	2.4	144	85
WS	P025D [] [] []	3/4	110	6.6	396	233
WS	P025E [] [] []	1	110	6.6	396	233
WS	P030G [] [] []	1 1/2	110	6.6	396	233
WS	P035G [] [] []	1 1/2	350	21.0	1260	742
WS	P040H [] [] []	2	350	21.0	1260	742
WS	P045I [] [] []	2 1/2	350	21.0	1260	742
WS	P050I [] [] []	2 1/2	800	48.0	2880	1695
WS	P055J [] [] []	3	800	48.0	2880	1695

CFP – Correction Factor Minimum Inlet Pressure (Water Separators)

Minimum Inlet Pressure	bar g	1	2	3	4	5	6	7	8	9	10	11	12	13	14	15	16
	psi g	15	29	44	58	73	87	100	116	131	145	160	174	189	203	218	232
Correction Factor		4.00	2.63	2.00	1.59	1.33	1.14	1.00	0.94	0.89	0.85	0.82	0.79	0.76	0.73	0.71	0.68

FILTER FLOW RATES

MODEL				PORT SIZE	L/S	M ³ /MIN	M ³ /HR	CFM	REPLACEMENT ELEMENT KIT		NO.	
[GRADE]	P010A	[]	[]	[]	1/4	10	0.6	36	21	P010	[Grade]	1
[GRADE]	P010B	[]	[]	[]	3/8	10	0.6	36	21	P010	[Grade]	1
[GRADE]	P010C	[]	[]	[]	1/2	10	0.6	36	21	P010	[Grade]	1
[GRADE]	P015C	[]	[]	[]	1/2	20	1.2	72	42	P015	[Grade]	1
[GRADE]	P020C	[]	[]	[]	1/2	30	1.8	108	64	P020	[Grade]	1
[GRADE]	P020D	[]	[]	[]	3/4	30	1.8	108	64	P020	[Grade]	1
[GRADE]	P025D	[]	[]	[]	3/4	60	3.6	216	127	P025	[Grade]	1
[GRADE]	P025E	[]	[]	[]	1	60	3.6	216	127	P025	[Grade]	1
[GRADE]	P030G	[]	[]	[]	1 1/2	110	6.6	396	233	P030	[Grade]	1
[GRADE]	P035G	[]	[]	[]	1 1/2	160	9.6	576	339	P035	[Grade]	1
[GRADE]	P040H	[]	[]	[]	2	220	13.2	792	466	P040	[Grade]	1
[GRADE]	P045I	[]	[]	[]	2 1/2	330	19.8	1188	699	P045	[Grade]	1
[GRADE]	P050I	[]	[]	[]	2 1/2	430	25.8	1548	911	P050	[Grade]	1
[GRADE]	P055I	[]	[]	[]	2 1/2	620	37.3	2232	1314	P055	[Grade]	1
[GRADE]	P055J	[]	[]	[]	3	620	37.3	2232	1314	P055	[Grade]	1

CFP – Correction Factor Minimum Inlet Pressure (Coalescing and Dry Particulate Filters)

Minimum Inlet Pressure	bar g	1	2	3	4	5	6	7	8	9	10	11	12	13	14	15	16	17	18	19	20
	psi g	15	29	44	58	73	87	100	116	131	145	160	174	189	203	218	232	248	263	277	290
Correction Factor		4.00	2.63	2.00	1.59	1.33	1.14	1.00	0.94	0.89	0.85	0.82	0.79	0.76	0.73	0.71	0.68	0.64	0.62	0.61	0.59

TECHNICAL DATA

MODEL	FILTER MODELS										MIN OPERATING PRESSURE		MAX OPERATING PRESSURE		MIN RECOMMENDED OPERATING TEMP		MAX RECOMMENDED OPERATING TEMP		
	BAR G	PSI G	BAR G	PSI G	°C	°F	°C	°F	°C	°F	°C	°F	°C	°F	°C	°F	°C	°F	
WS	P010	[]	[]	F	[]	-	055	[]	[]	F	[]	1	15	16	232	2	35	80	176
AO	P010	[]	[]	F	[]	-	055	[]	[]	F	[]	1	15	16	232	2	35	80	176
AO	P010	[]	[]	M	[]	-	055	[]	[]	M	[]	1	15	20	290	2	35	100	212
AA	P010	[]	[]	F	[]	-	055	[]	[]	F	[]	1	15	16	232	2	35	80	176
AA	P010	[]	[]	M	[]	-	055	[]	[]	M	[]	1	15	20	290	2	35	100	212
ACS	P010	[]	[]	M	[]	-	055	[]	[]	M	[]	1	15	20	290	2	35	50	122

Note: AO / AA / WS grade filters for use up to 16 bar g (232 psi g) are supplied with a float drain [F] as standard. For pressures between 16 and 20 bar g (232 and 290 psi g) a manual drain [M] must be used. ACS grade filters are supplied with a manual drain [M] as standard.

WATER SEPARATOR WEIGHTS AND DIMENSIONS

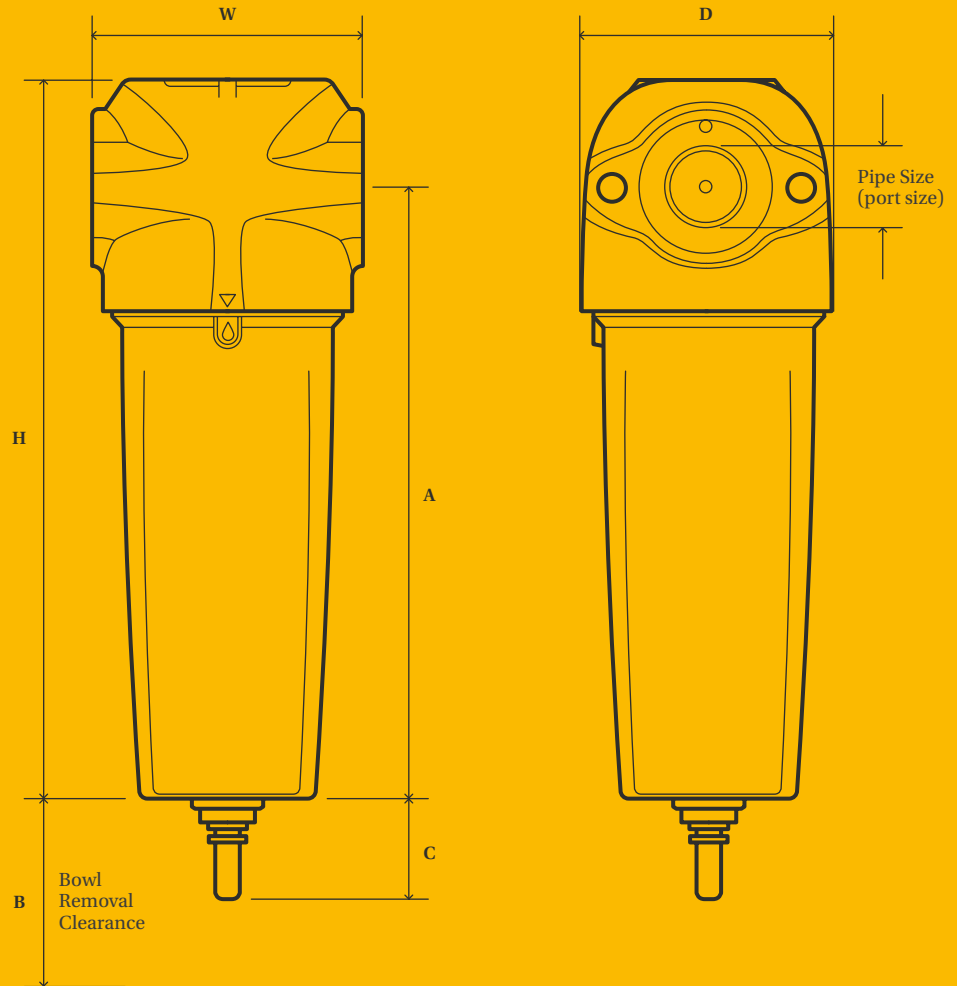

WATER SEPARATOR WEIGHTS AND DIMENSIONS

MODEL	PIPE SIZE	HEIGHT (H)		WIDTH (W)		DEPTH (D)		(A)		(B)		(C)		WEIGHT	
		MM	INS	MM	INS	MM	INS	MM	INS	MM	INS	MM	INS	KG	LBS
WSP010A	1/4	180	7.09	76	2.99	65	2.56	154	6.06	50	1.97	38	1.5	0.80	1.76
WSP010B	3/8	180	7.09	76	2.99	65	2.56	154	6.06	50	1.97	38	1.5	0.79	1.75
WSP010C	1/2	180	7.09	76	2.99	65	2.56	154	6.06	50	1.97	38	1.5	0.78	1.72
WSP015C	1/2	238	9.37	89	3.5	84	3.31	202	7.95	50	1.97	38	1.5	1.08	2.39
WSP020D	3/4	238	9.37	89	3.5	84	3.31	202	7.95	50	1.97	38	1.5	1.35	2.98
WSP025D	3/4	277	10.91	120	4.72	115	4.53	232	9.13	70	2.76	38	1.5	2.64	5.83
WSP025E	1	277	10.91	120	4.72	115	4.53	232	9.13	70	2.76	38	1.5	2.64	5.83
WSP030G	1 1/2	277	10.91	120	4.72	115	4.53	232	9.13	70	2.76	38	1.5	2.54	5.61
WSP035G	1 1/2	440	17.32	164	6.46	157	6.18	383	15.08	100	3.94	38	1.5	6.69	14.74
WSP040H	2	440	17.32	164	6.46	157	6.18	383	15.08	100	3.94	38	1.5	6.46	14.23
WSP045I	2 1/2	440	17.32	164	6.46	157	6.18	383	15.08	100	3.94	38	1.5	6.28	13.85
WSP050I	2 1/2	516	20.31	192	7.56	183	7.20	444	17.48	120	4.72	40	1.57	10.80	23.81
WSP055J	3	516	20.31	192	7.56	183	7.20	444	17.48	120	4.72	40	1.57	10.83	23.89

Note: Water Separators do not include a DP Indicator, use dimension H + C for the total height.

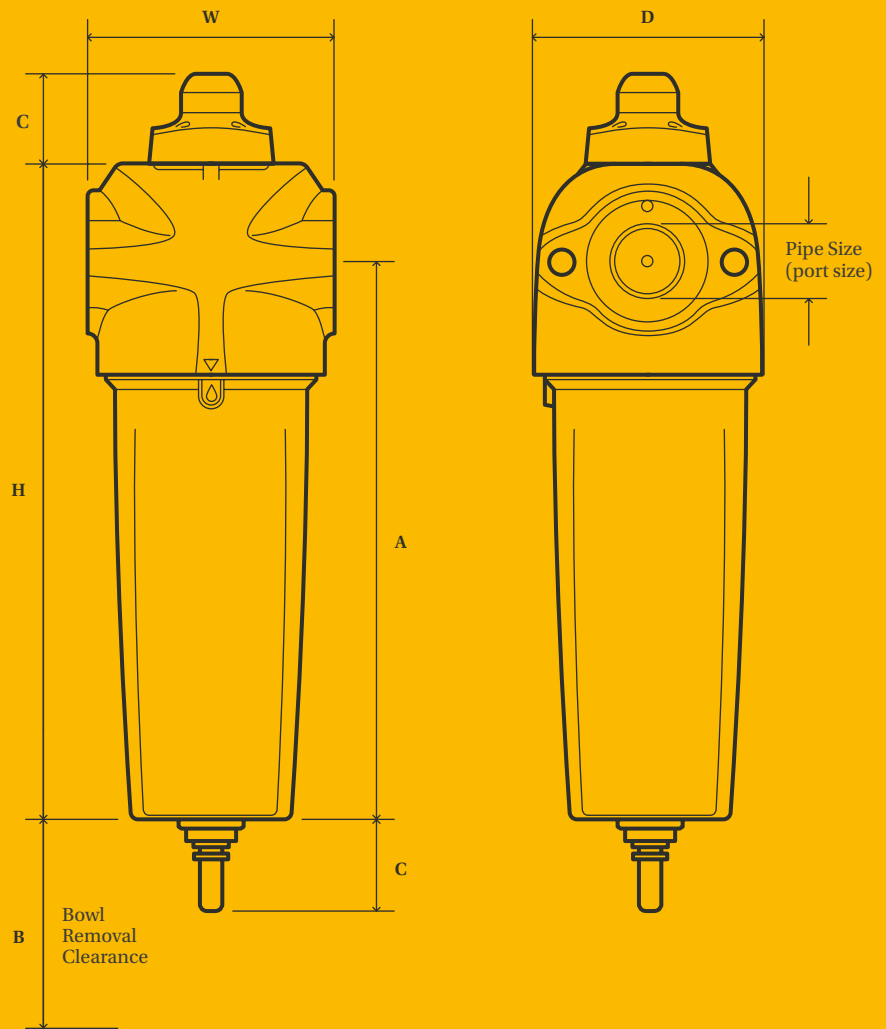

FILTER WEIGHTS AND DIMENSIONS



FILTER WEIGHTS AND DIMENSIONS

MODEL	PIPE SIZE	HEIGHT (H)		WIDTH (W)		DEPTH (D)		(A)		(B)		(C)		WEIGHT	
		MM	INS	MM	INS	MM	INS	MM	INS	MM	INS	MM	INS	KG	LBS
P010A	1/4	180	7.09	76	2.99	65	2.56	154	6.06	50	1.97	32	1.5	0.84	1.86
P010B	3/8	180	7.09	76	2.99	65	2.56	154	6.06	50	1.97	32	1.5	0.84	1.86
P010C	1/2	180	7.09	76	2.99	65	2.56	154	6.06	50	1.97	32	1.5	0.82	1.81
P015C	1/2	238	9.37	89	3.5	84	3.31	202	7.95	50	1.97	32	1.5	1.16	2.55
P020C	1/2	238	9.37	89	3.5	84	3.31	202	7.95	50	1.97	38	1.5	1.17	2.58
P020D	3/4	238	10.91	89	3.5	84	3.31	202	7.95	50	1.97	32	1.5	1.44	3.19
P025D	3/4	277	10.91	120	4.72	115	4.53	232	9.13	70	2.76	32	1.5	2.14	4.71
P025E	1	277	10.91	120	4.72	115	4.53	232	9.13	70	2.76	32	1.5	2.69	5.92
P030G	1 1/2	367	14.45	120	4.72	115	4.53	322	12.68	70	2.76	32	1.5	3.04	6.70
P035G	1 1/2	440	17.32	164	6.46	157	6.18	383	15.07	100	3.94	68	1.5	6.90	15.21
P040H	2	532	20.94	164	6.46	157	6.18	475	18.7	100	3.94	68	1.5	7.30	16.09
P045I	2 1/2	532	20.94	164	6.46	157	6.18	475	18.7	100	3.94	68	1.5	7.10	15.65
P050I	2 1/2	654	25.75	192	7.56	183	7.20	582	22.91	120	4.72	68	1.57	10.30	22.71
P055I	2 1/2	844	33.23	192	7.56	183	7.20	772	30.39	120	4.72	68	1.57	15.9	35.05
P055J	3	844	33.23	192	7.56	183	7.20	772	30.39	120	4.72	68	1.57	15.30	33.73

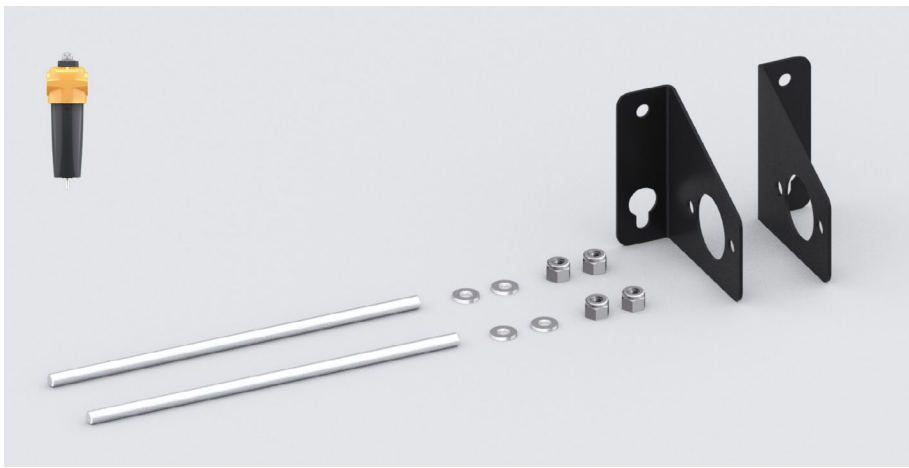
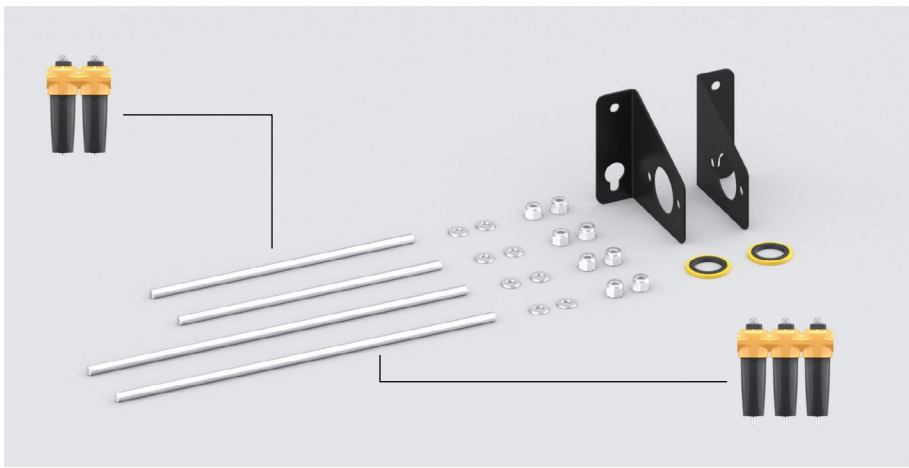
ACCESSORIES / SPARE PARTS (SERVICE KITS)

FILTER MODELS	CAT NO.	CONTENTS			
010	TRK1-2				
015 - 020	TRK2-2				
025 - 030	TRK3-2				
035 - 045	TRK4-2				
050 - 055	TRK5-2				
010	MBK1-1				
015 - 020	MBK2-1				
025 - 030	MBK3-1				
035 - 045	MBK4-1				
050 - 055	MBK5-1				
010	MBK1-2				
015 - 020	MBK2-2				
025 - 030	MBK3-2				
035 - 045	MBK4-2				
050 - 055	MBK5-2				
010 - 030	DPI-K		010 - 055	PD15NO	
035 - 055	ZD90GL		010 - 055	EM1	

ONE YEAR AIR QUALITY GUARANTEE

Your air quality has been guaranteed for 1 year and will be renewed at every annual filter element change.

Annual filter element changes ensure:

- Optimal performance is maintained
- Air quality continues to meet international standards
- Protection of downstream equipment, personnel and processes
- Low operational costs
- Increased productivity and profitability
- Peace of mind

